



## PWCキット-ウェイクボードラック

製品：	Sea-Doo_watercraft
プロジェクト番号：	487802623_rev1
取扱説明書P/N：	487802623
リビジョン番号：	1
改訂日：	2019年2月
対象品目：	ウェイクボードラック

このドキュメントでは、次の記号を使用できます。

### 警告

回避しないと、死亡または重傷を負う可能性がある危険な状況を示します。

**▲注意：** 回避しないと、軽傷または中程度の傷害を招く可能性がある危険な状況を示します。

**通知** 従わない場合、車両のコンポーネントやその他の資産に重大な損傷を与える可能性のある指示を示します。

### 警告

- 安全上の理由から、このキットは認定BRP販売店が取り付ける必要があります。
- このキットは、特定の適用モデル専用に設計されています（認定BRPディーラーがモデルを確認します）。販売されたユニット（ユニット）以外のユニットにはお勧めできません。
- 分解/組み立ての際にロック装置（ロックタブ、セルフロックファスナーなど）の取り外しが必要な場合は、必ず新しいものと交換してください。
  - ・トルクレンチの締付け仕様を厳守してください。
- 電動工具を使用するときは、常に眼の保護と適切な手袋を着用してください。

### 警告

エンドユーザー向けの重要な安全情報や操作手順が、この手順シートに含まれている場合があります。必ず、キットの部品番号と、このキットに含まれている指示シートをお客様に提供してください。お客様がアクセサリを適切に使用するために必要なすべての情報にアクセスできることを確認します。

**NOTE:** USE TIGHTENING TORQUES IN THE FOLLOWING TABLE IF NOT OTHERWISE SPECIFIED.



	GRADE			
	5.8	8.8	10.9	12.9
M4	1.8 ± 0.2 N•m (16 ± 2 lbf•in)	2.8 ± 0.2 N•m (25 ± 2 lbf•in)	3.8 ± 0.2 N•m (34 ± 2 lbf•in)	4.5 ± 0.5 N•m (40 ± 4 lbf•in)
M5	3.3 ± 0.2 N•m (29 ± 2 lbf•in)	5 ± 0.5 N•m (44 ± 4 lbf•in)	7.8 ± 0.7 N•m (69 ± 6 lbf•in)	9 ± 1 N•m (80 ± 9 lbf•in)
M6	7.5 ± 1 N•m (66 ± 9 lbf•in)	10 ± 2 N•m (89 ± 18 lbf•in)	12.8 ± 2.2 N•m (113 ± 19 lbf•in)	16 ± 2 N•m (142 ± 18 lbf•in)

M8	15.3 ± 1.7 N•m (135 ± 15 lbf•in)	24.5 ± 3.5 N•m (18 ± 3 lbf•ft)	31.5 ± 3.5 N•m (23 ± 3 lbf•ft)	40 ± 5 N•m (30 ± 4 lbf•ft)
M10	29 ± 3 N•m (21 ± 2 lbf•ft)	48 ± 6 N•m (35 ± 4 lbf•ft)	61 ± 9 N•m (45 ± 7 lbf•ft)	73 ± 7 N•m (54 ± 5 lbf•ft)
M12	52 ± 6 N•m (38 ± 4 lbf•ft)	85 ± 10 N•m (63 ± 7 lbf•ft)	105 ± 15 N•m (77 ± 11 lbf•ft)	128 ± 17 N•m (94 ± 13 lbf•ft)
M14	85 ± 10 N•m (63 ± 7 lbf•ft)	135 ± 15 N•m (100 ± 11 lbf•ft)	170 ± 20 N•m (125 ± 15 lbf•ft)	200 ± 25 N•m (148 ± 18 lbf•ft)
M16	126 ± 14 N•m (93 ± 10 lbf•ft)	205 ± 25 N•m (151 ± 18 lbf•ft)	255 ± 30 N•m (188 ± 22 lbf•ft)	305 ± 35 N•m (225 ± 26 lbf•ft)
M18	170 ± 20 N•m (125 ± 15 lbf•ft)	273 ± 32 N•m (201 ± 24 lbf•ft)	330 ± 25 N•m (243 ± 18 lbf•ft)	413 ± 47 N•m (305 ± 35 lbf•ft)

**NOTE:** The illustrations in this document show typical construction of the different assemblies and may not reproduce the full detail or exact shape of the parts; however, they represent parts that have the same or similar function.

**NOTE:** Installation time is approximately 0.5 hour.

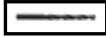
## REQUIRED TOOLS

Required Tool		Use
T1	Drill bit 5.5 mm (7/32 in) 	To drill holes for M6.81 x 25 and M6.81 x 30 Torx screw
T2	Center punch 	To punch the center of the holes for M6.81 x 25 and M6.81 x 30 Torx screw

## PARTS TO BE INSTALLED

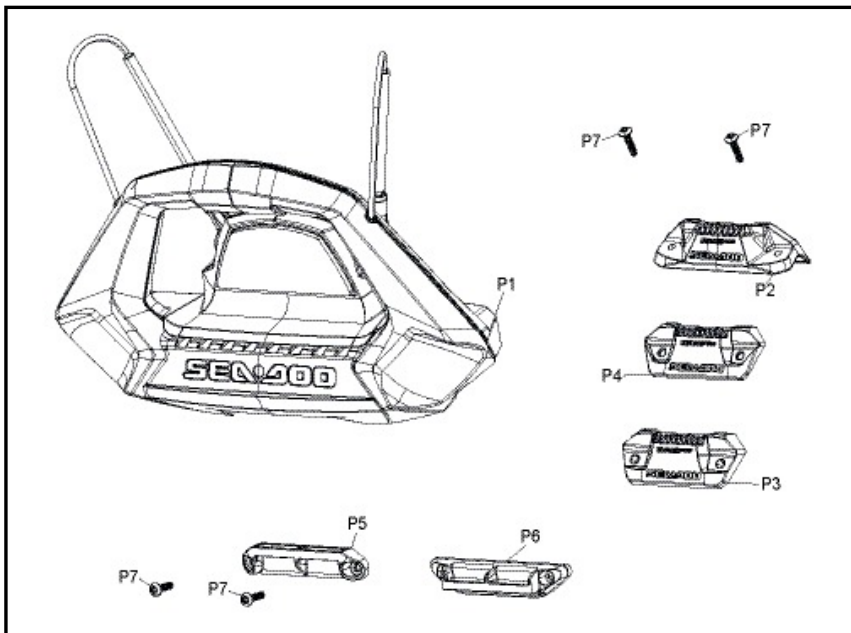

ITEM	DESCRIPTION	Part number	QTY
P1	Board Support Kit	291002854	1
P2	Upper Anchor	291003582	1

P3	Upper Anchor	291003104	1
P4	Upper Anchor	291004675	1
P5	Lower Anchor	291004769	1
P6	Lower Anchor	291002864	1
P7	M6.81 x 30 Torx Screw	250000709	4
P8	Warning Decal (FR) (not shown)	219903229	1

**NOTICE** Prior to operate the vehicle with the new features, it is of a prime importance to understand the Operator's Guide instructions provided with the vehicle. If this guide is not available on your side, ask to your dealer to get a free sample.

## INSTRUCTIONS

### Upper Anchor Installation

1. Select vehicle side onto which you want to install the wakeboard rack.
2. Put the superior anchor in place. Refer to the following table for distance and proper support according to model.

Models	Upper Anchor	Measured distance from rear Bumper	Item
GTX, RXT and Wake Pro MY18 and up	291004675	760 mm (30 in)	P4

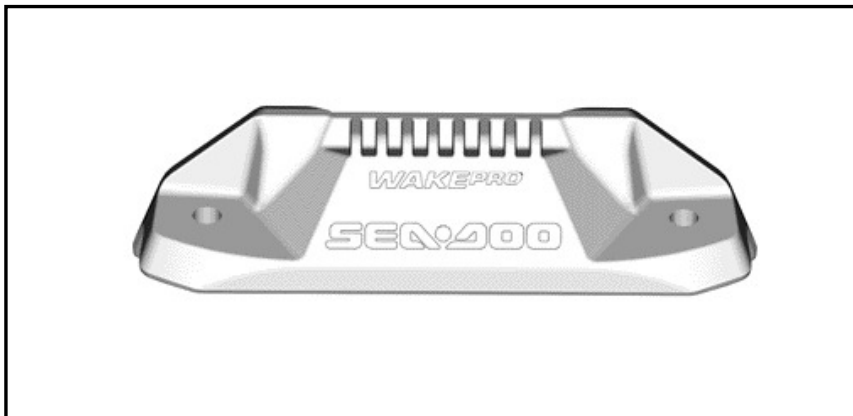

UPPER ANCHOR (P/N 291004675)

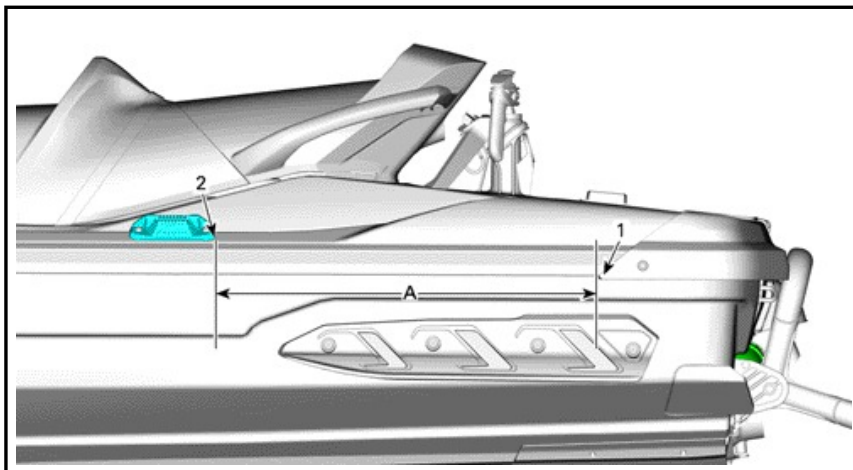

GTX RXT 2018 AND WAKE PRO 2018 AND UP

A = Distance

1. Rear bumper end

2. Distance measured

3. Mark the center of the two holes.

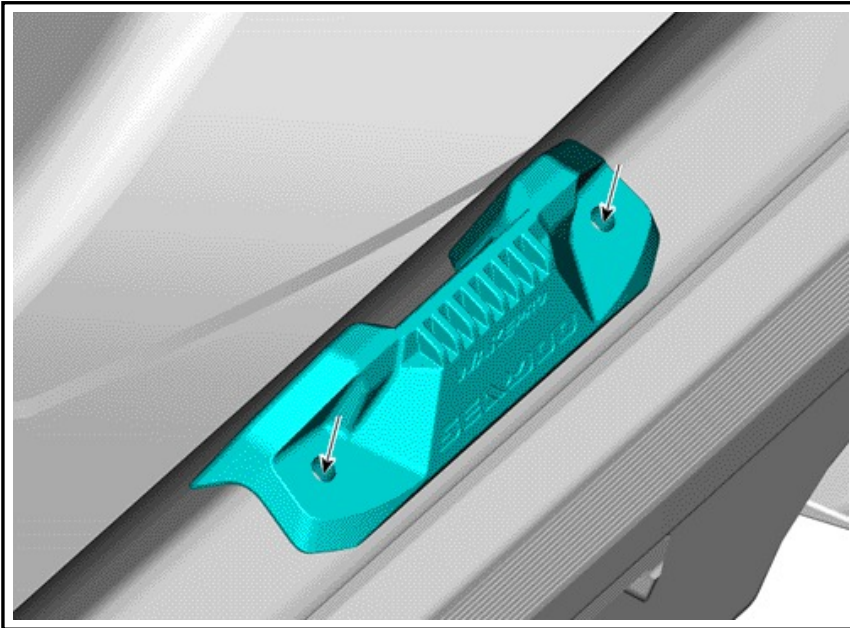

- 4. Punch with the center punch [T2] and pierce the two holes with the drill bit [T1].
- 5. Remove the debris.
- 6. Apply CLEAR SILICONE SEALANT (P/N 296 000 309) in each holes.
- 7. Place the upper anchor and fix it with M6.81 x 30 torx screw [P7].

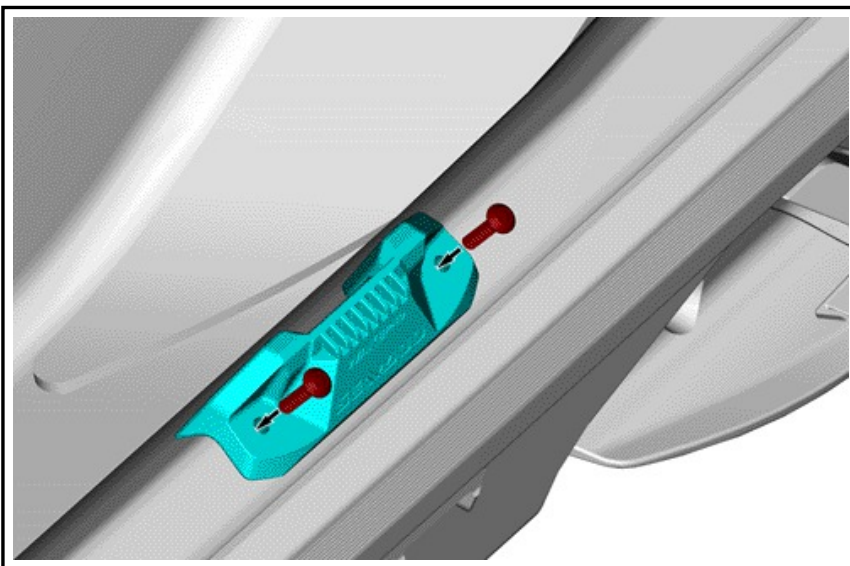

Tightening Torque	
M6.81 x 30 Torx Screw [P7]	4.5 to 5.5 N•m (40 to 49 lbf•in)

### Upper Anchor Installation

- 1. Select vehicle side onto which you want to install the wakeboard rack.
- 2. Measure a distance from the end of the rear bumper, parallel to the top edge of the side bumper. Refer to table for distance and proper support according to model.

Models	Upper support	Measured distance from rear bumper	Item
GTX, RXT and Wake Pro MY17 and older	291003582	636 mm (25 in)	P2
GTI and GTR	291003104	760 mm (30 in)	P3

Models	Upper support	Measured distance from rear bumper	Item

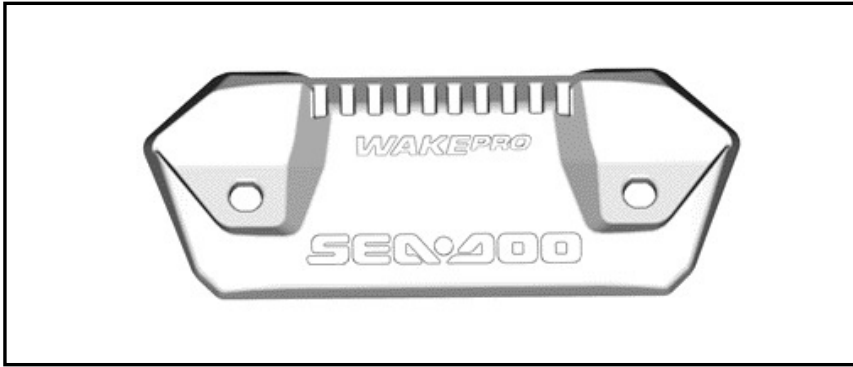

UPPER ANCHOR (P/N 291003582)

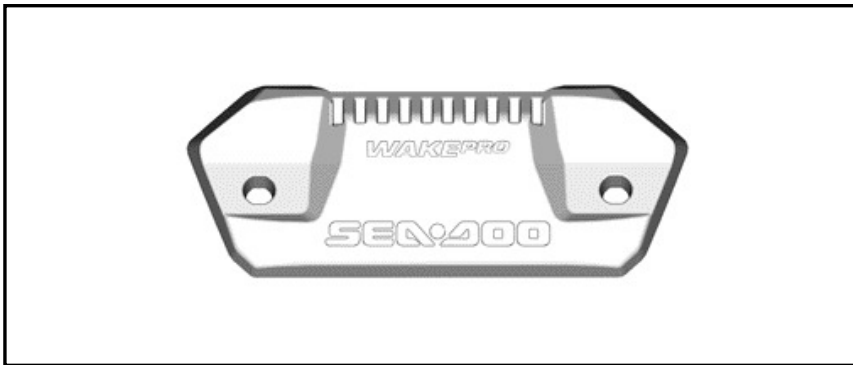

UPPER ANCHOR (P/N 291003104)



- 1. End of rear bumper
- 2. Measured distance

**NOTE:** The tape measure should be aligned to be tangent with the rounded end of the rear bumper.

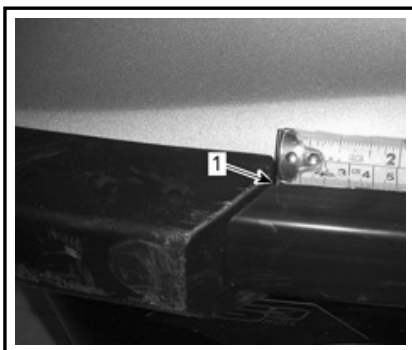

- 1. Tangent location for measure origin

3. Mark the measured distance on the watercraft deck just above bumper line using a marker.



*MEASURE AND MARK DISTANCE FROM REAR BUMPER*

4. Measure and mark a dot on the deck at a distance of 30 mm (1.18 in) above the preceding location. This mark represents the location of the rear hole.

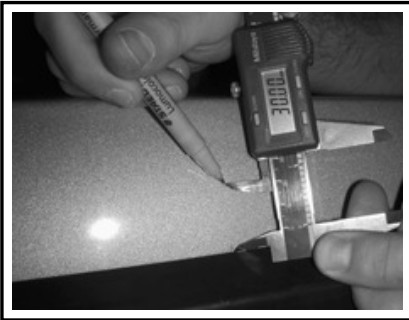

*30 MM OFFSET*

5. Measure a second offset of  $30 \pm 0.5$  mm ( $1.181 \pm .02$  in) above the bumper at a distance of approximately 75 mm (3 in) further towards the front of the deck.

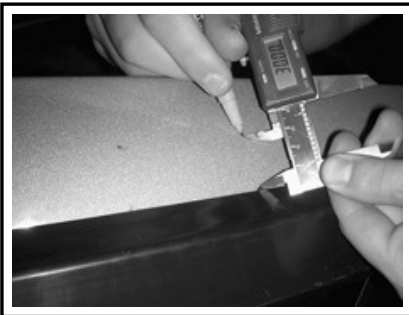

*30 MM OFFSET*

6. Draw a line parallel to the bumper and passing through the two points towards the front of the watercraft of at least 115 mm (4.5 in) long.



*1. Line parallel to bumper*

7. Punch and drill a #3 (5.5mm) diameter hole at the first location marked towards rear of watercraft (rear hole).

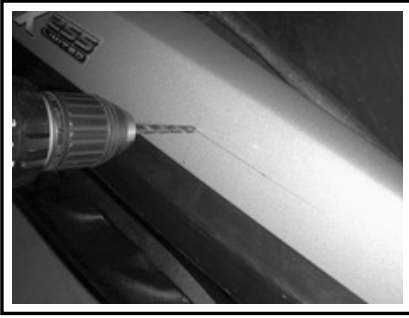

*PUNCH AND DRILL HOLE*

8. Install one of the retaining screws [P4] to temporarily affix the appropriate upper anchor [P3] to the deck as a centering aid to locate the second hole.

**NOTE:** Do not torque retaining screw yet.

**NOTICE** Make sure to use the proper support adapter for your vehicle prior to drilling holes in deck.

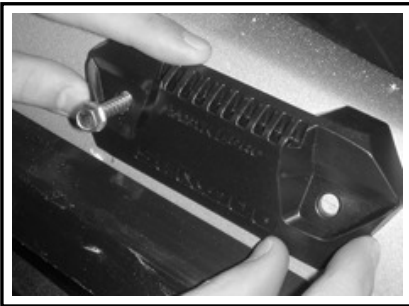

*TEMPORARILY AFFIXED UPPER ANCHOR*

9. Punch and drill a #3 (5.5mm) diameter hole on the center line towards the front of the watercraft using the anchor as a template.



*PUNCH AND DRILL HOLE*

10. Clean residues.

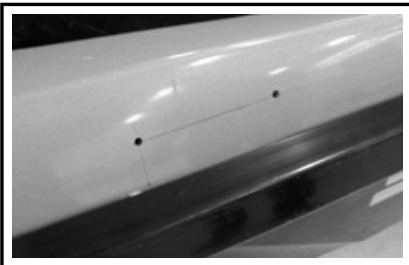

*CLEAN RESIDUES*

11. Apply a bead of CLEAR SILICONE SEALANT (P/N 296 000 309) in each hole.



APPLY SEALANT

12. Install upper anchor. Tighten screws to  $6 \pm 1 \text{ N}\cdot\text{m}$  ( $53 \pm 9 \text{ lbf}\cdot\text{in}$ ).



INSTALLED UPPER ANCHOR

### Lower Anchor Installation

1. Install lower anchor onto the wake support [P1]. Refer to the following table for distance and proper support according to model.

Models	Lower Anchor	Item
GTX, RXT and Wake Pro MY18 and up	291004769	P5
GTX, RXT and Wake Pro MY17 and older	291002864	P6
GTI and GTR	291002864	P6

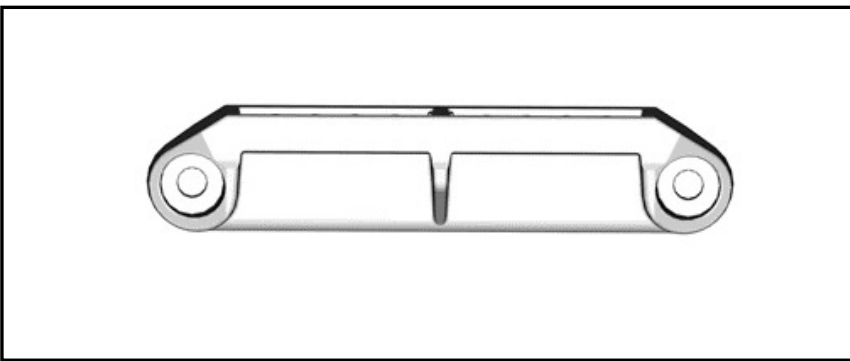

LOWER ANCHOR (P/N 291004769)

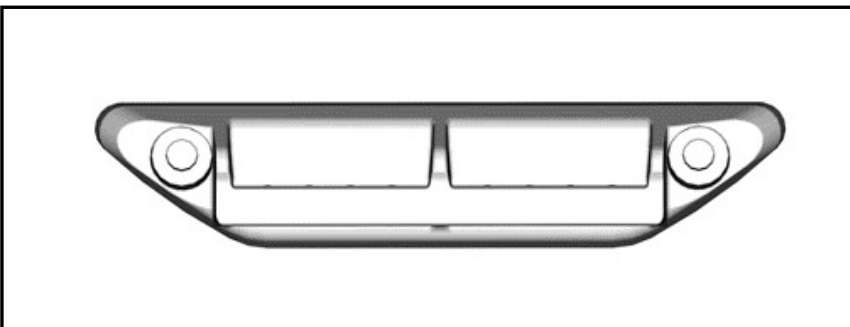

LOWER ANCHOR (P/N 291002864)





A = Lower anchor  
B = Wake support

2. Install wake support latch onto the upper anchor.
3. Apply pressure downwards on the wake support so it rests against the bumper of the watercraft.
4. While maintaining pressure, push lower anchor towards hull until it rests against it.
5. Mark a line on the hull around the lower anchor.

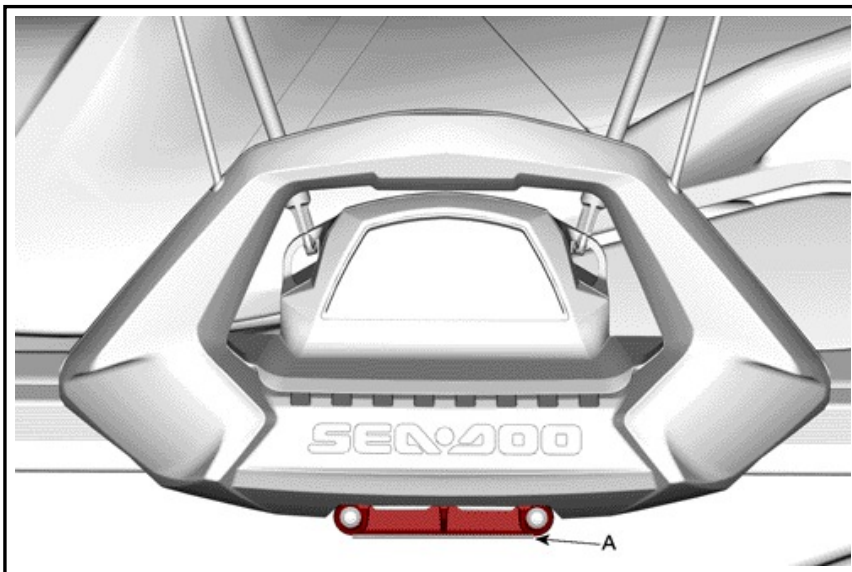

A = Mark a line here

6. Remove the wake support from the upper anchor and remove the lower anchor from the wake support.
7. Reposition the lower anchor to its marked location to use it as a template for drilling.
8. Punch with the center punch [T2] and Drill with the drill bit [T1]. Only on one side.

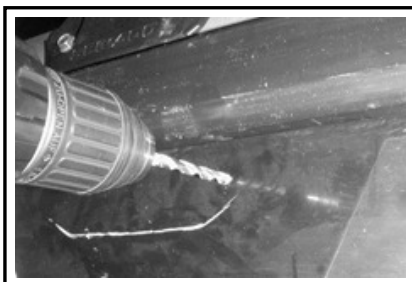

PUNCH AND DRILL HOLE

9. Remove debris.

- 10. Apply a bead of CLEAR SILICONE SEALANT (P/N 296 000 309) in hole.
- 11. Affix the lower anchor with the first M6.81 x 30 torx screw [P7].
- 12. Use the lower anchor as a template to punch with the center punch [T2] and drill with the drill bit [T1] the other hole..

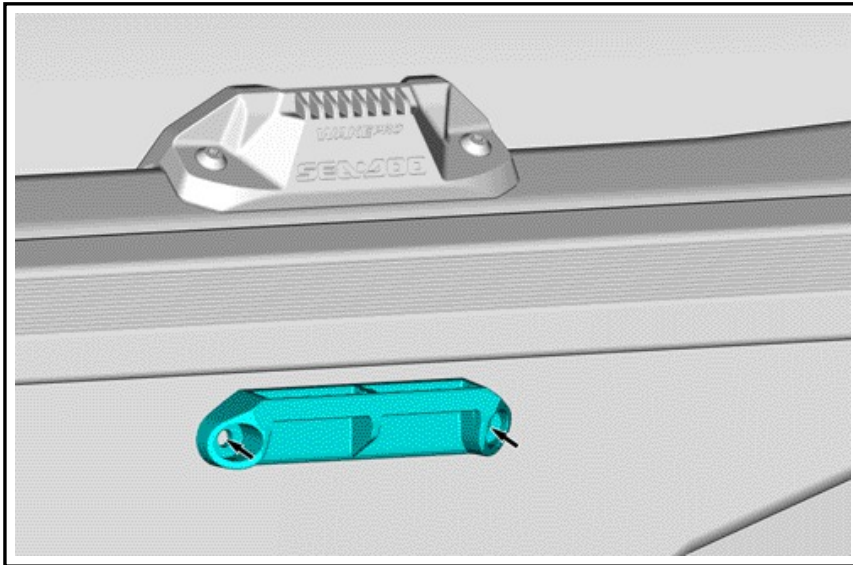

- 13. Remove debris.
- 14. Apply a bead of CLEAR SILICONE SEALANT (P/N 296 000 309) in each hole.

- 15. Install lower anchor and tighten M6.81 x 30 torx screws [P7] .

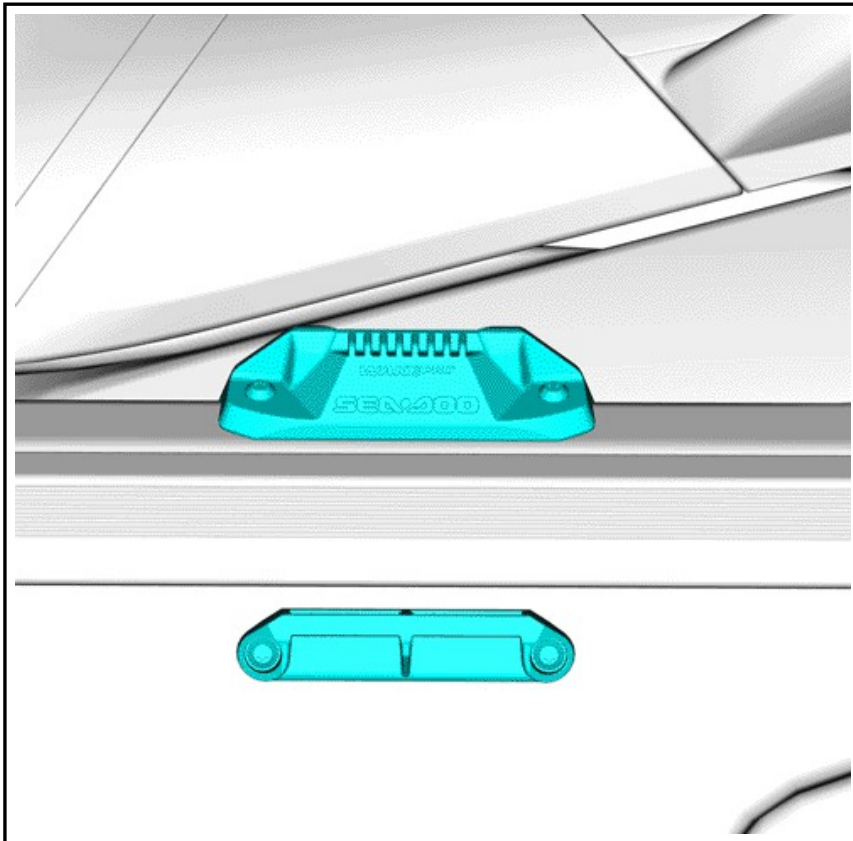

*BOTH ANCHORS ARE INSTALLED*

Tightening Torque	
M6.81 x 30 Torx Screw [P7]	4.5 to 5.5 N•m (40 to 49 lbf•in)

## Wake Support Installation

1. Install wake support onto lower anchor.

**NOTICE** Ensure wake support and lower anchor are well engaged together before to rotate the wake support to avoid damage to both parts.



WAKE SUPPORT AFFIXED TO LOWER ANCHOR

2. Rotate wake support upwards and push to snap onto the upper anchor.



WAKE SUPPORT AFFIXED TO UPPER ANCHOR

## Warning Label

This product comes with the following, already apposed, English warning label containing important safety information. For the other languages, see with your certified BRP dealer.



The warning label should be considered permanent part of this product. If the label comes off or becomes hard to read, please contact an authorized dealer for replacement.

Any person who intends to use this product should read and understand the information contained on the warning label before doing so.

## Warning Label Installation

1. Install the French warning label [P9] when necessary.

**NOTICE** Do not apply isopropyl alcohol or solvent directly on labels.

2. ラベルを取り付けるには、きれいな乾いた布で既存のラベルの表面を拭き取ります。
3. 警告ラベルを貼り付けます。



1.警告ラベル